

November / Novembre 2016

CometNews

EWD-K

High pressure triplex pump for petrol engines
Pompa triplex ad alta pressione per motori a benzina



High-pressure cleaning
Pulizia ad alta pressione

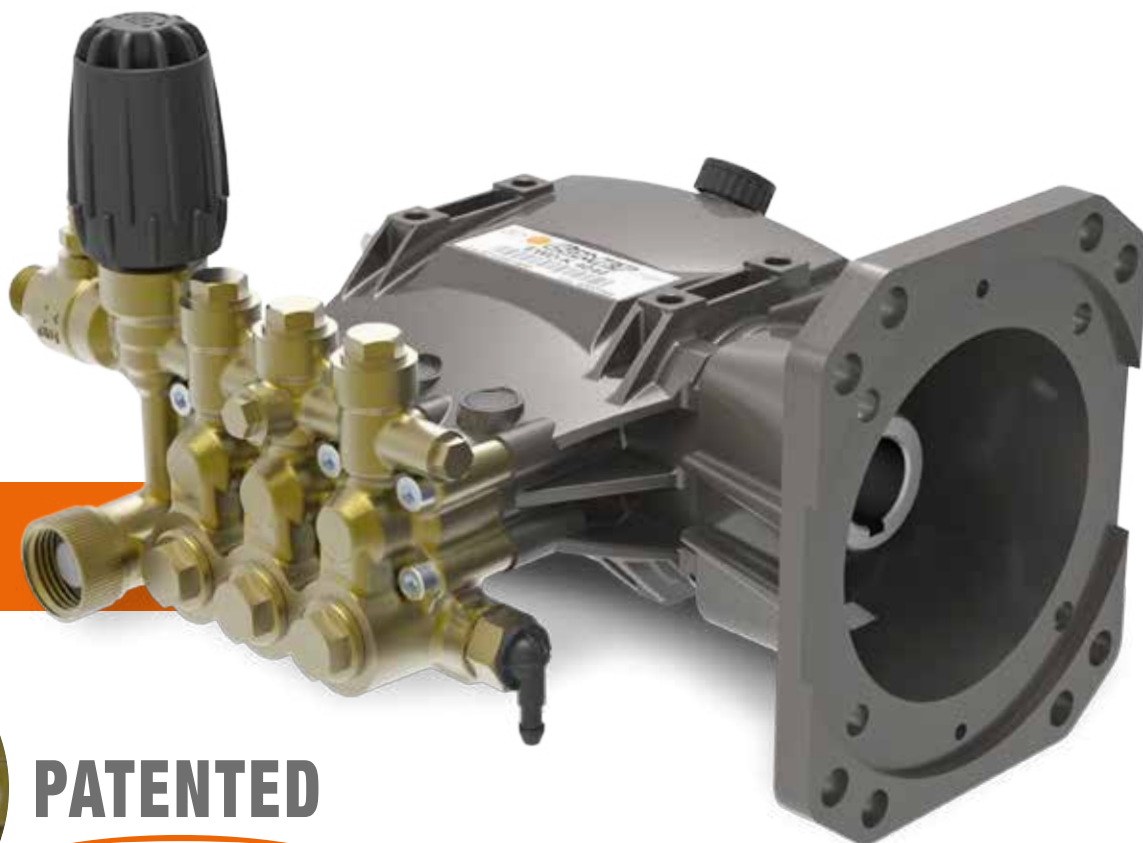

Optional
**PRESSURE
BOOSTER**



PATENTED

EWD-K



Wide **OIL LEVEL** viewer
Ampio visore **OLIO**

STAINLESS-STEEL HARDENED piston guides
*Guide pistoni **IN ACCIAIO INOX TEMPERATO***

Unloader valve knob with
ANTI-UNSCREWING DEVICE
Manopola valvola di regolazione con
DISPOSITIVO ANTISVITAMENTO

High-strength **BRASS PUMP**
MANIFOLD with integrated
unloader valve and prearranged for:
- detergent suction
- pressure gauge
- thermostat valve
- Pressure Booster

TESTATA IN OTTONE ad alta resistenza
con valvola di regolazione integrata
e predisposizione per:
- aspirazione detergente
- manometro
- valvola termostatica
- Pressure Booster

PATENTED



Highly efficient **STAINLESS STEEL**
CHECK VALVES with removable
plugs for easy inspection

VALVOLE DI ASPIRAZIONE E MANDATA
ad alta efficienza **IN ACCIAIO INOX** con
tappi rimovibili per facilitare l'ispezione

DELIVERY VALVES with **DOUBLE**
O-RING to reduce overpressure risks
VALVOLE DI MANDATA con **DOPPIA**
TENUTA O-RING per minimizzare
i rischi di sovrappressione

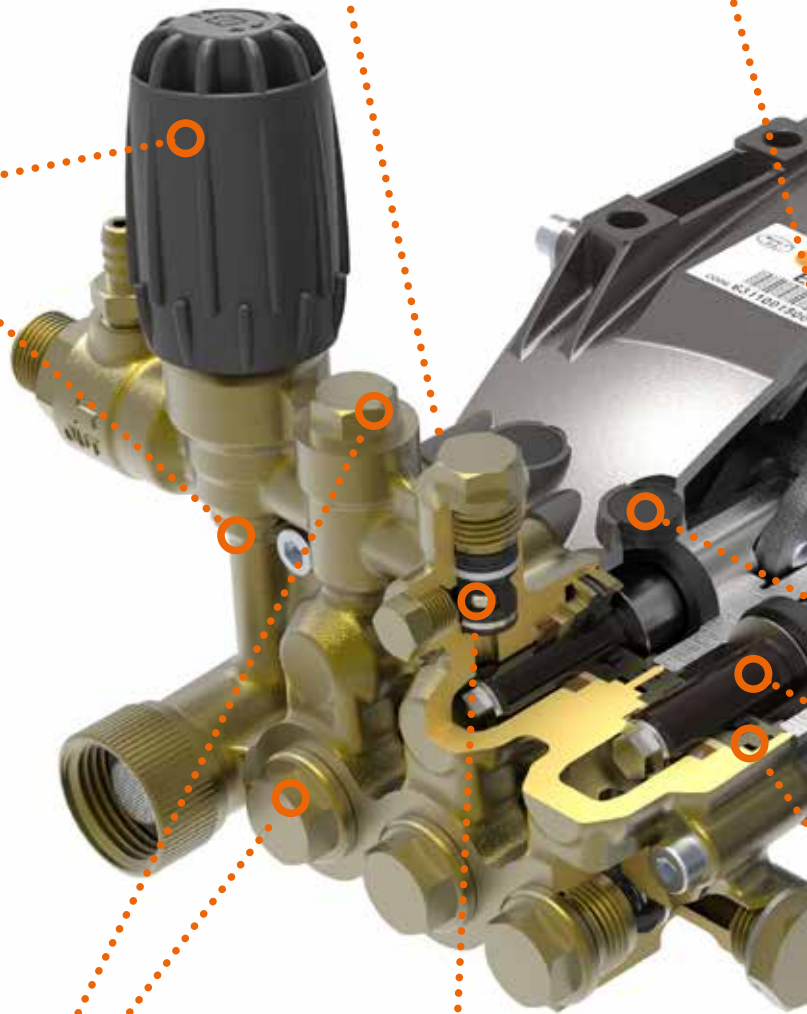

Efficiency Well Done

Efficienza e Qualità

New designed **REVERSIBLE CARTER**
made in special aluminum alloy

*Nuovo design del **CARTER REVERSIBILE**
in lega di alluminio anodizzato*

O-RING and labirinth **OIL SEAL SYSTEM**
between crankcase and rear cover,
to reduce oil splashing

***SISTEMA DI TENUTA** tra carter
e coperchio con **O-RING** e labirinto,
per ridurre lo sbattimento d'olio*

SPECIAL ALUMINIUM ALLOY
CONRODS made in a double piece
***BIELLE** in due pezzi realizzate in
SPECIALE LEGA DI ALLUMINIO*

Top-quality and oversized
CONICAL ROLLER BEARINGS
to ensure long durability
***CUSCINETTI A RULLI CONICI**
ad alta qualità e sovradimensionati
per garantire una maggiore durata*

1" HOLLOW SHAFT
with flange for coupling
to petrol engines
***ALBERO FEMMINA 1"**
con flangia per accoppiamento
con motori a benzina*

SPECIAL PLUGS for dust protection
***TAPPI SPECIALI** antipolvere*

High performance
DOUBLE SEALING SYSTEM
***DOPPIO SISTEMA DI GUARNIZIONE**
ad alta resistenza*

SOLID CERAMIC PLUNGERS,
high corrosion and abrasion-proof
***PISTONI IN CERAMICA INTEGRALE,**
per una resistenza superiore
all'abrasione e alla corrosione*

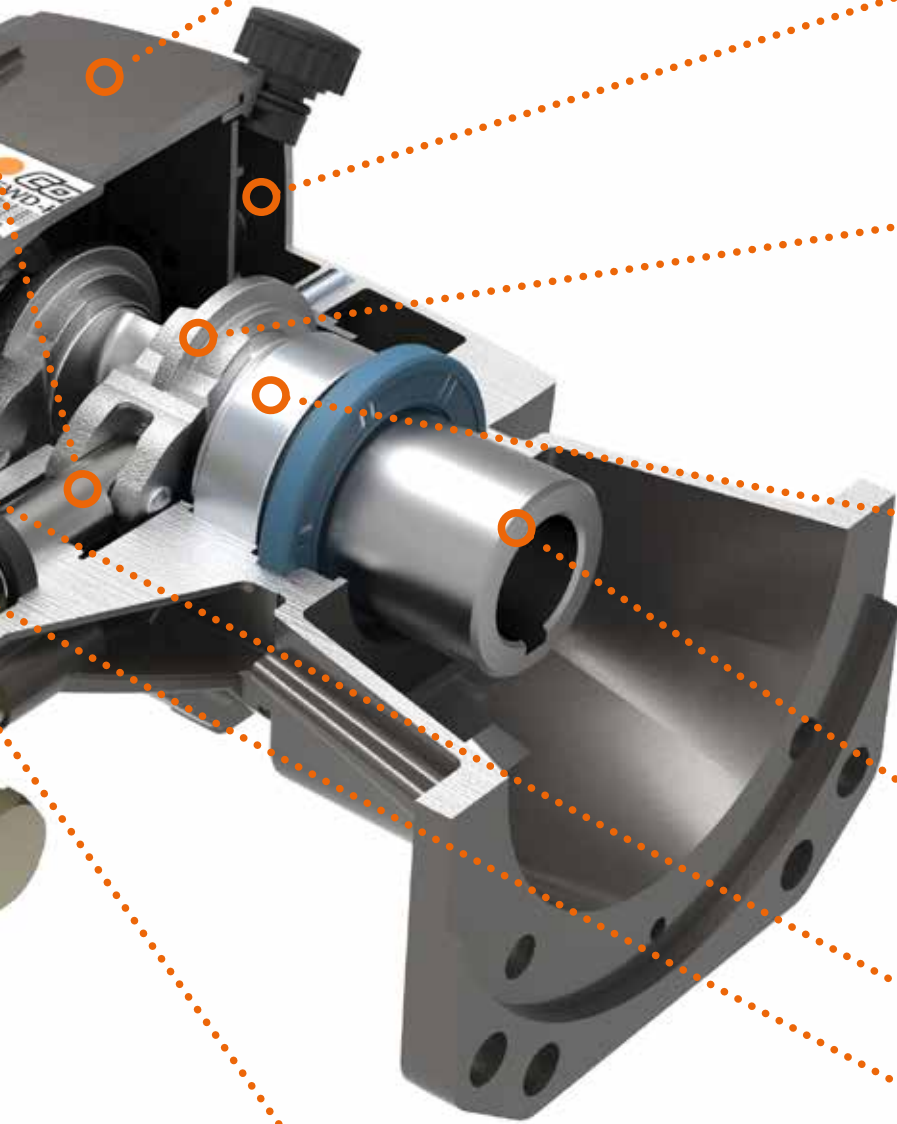

TECHNICAL DATA / DATI TECNICI

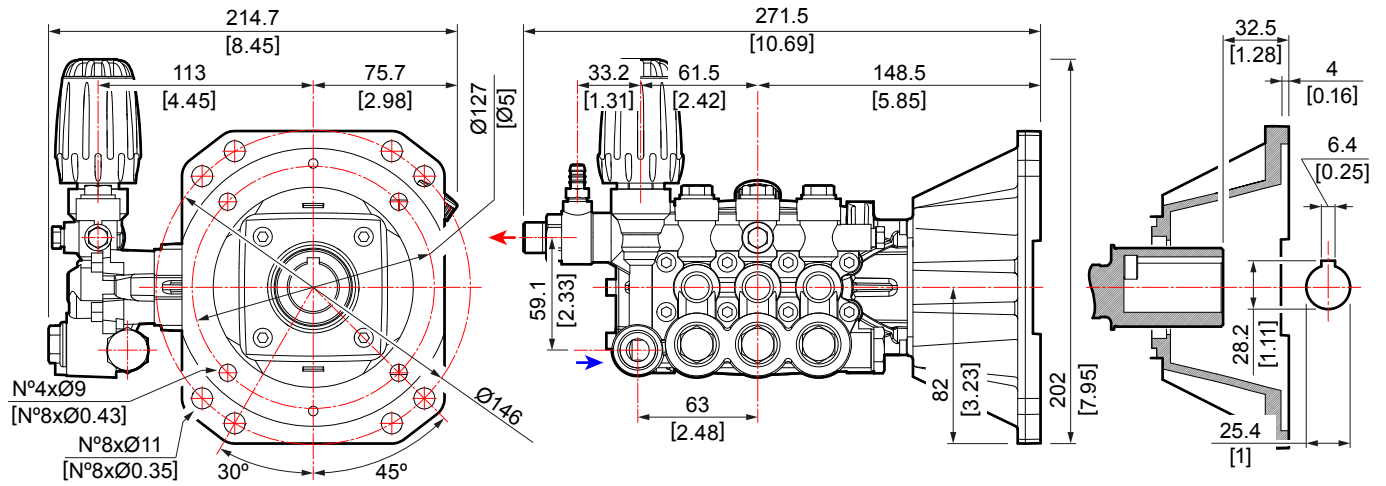

Code Codice	Model Modello	Version Versione	Flow				Pressure			Power		Weight	
			“	rpm	l/min	U.S.g.p.m.	bar	psi	Mpa	HP	kW	kg	lb
6311 0250	EWD-K 3540 G	1	3400	13,0	3,4	276	4000	27,6	9,5	7,0	6,5	14,4	
6311 0150	EWD-K 4040 G	1	3400	15,0	4,0	276	4000	27,6	11,0	8,2	6,5	14,4	

Follow us on



Comet, Italian Excellence



COMPANY
WITH QUALITY SYSTEM
CERTIFIED BY DNV
= ISO 9001/2008 =